

**MBIT103**  
**CHASSIS 2WD POUR MICRO BIT**

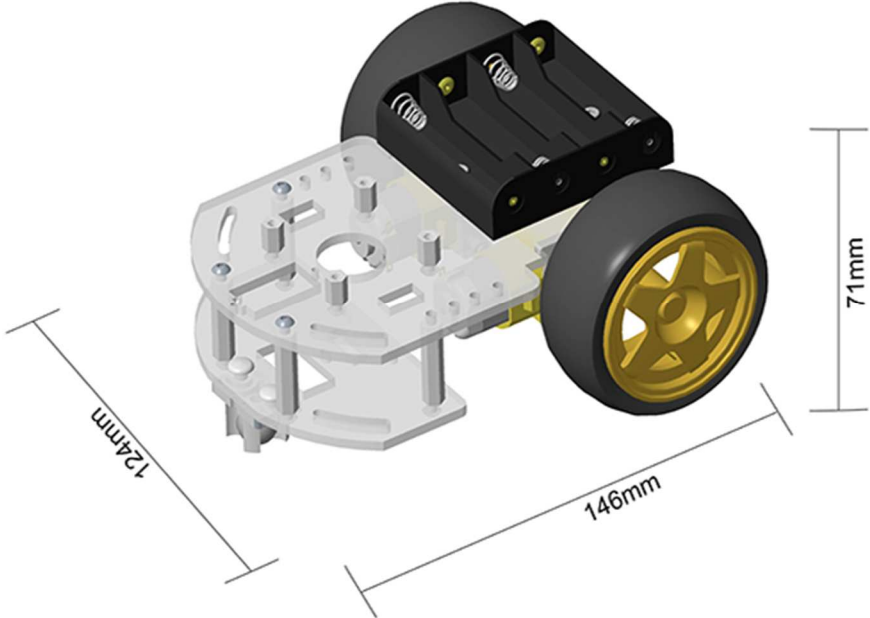

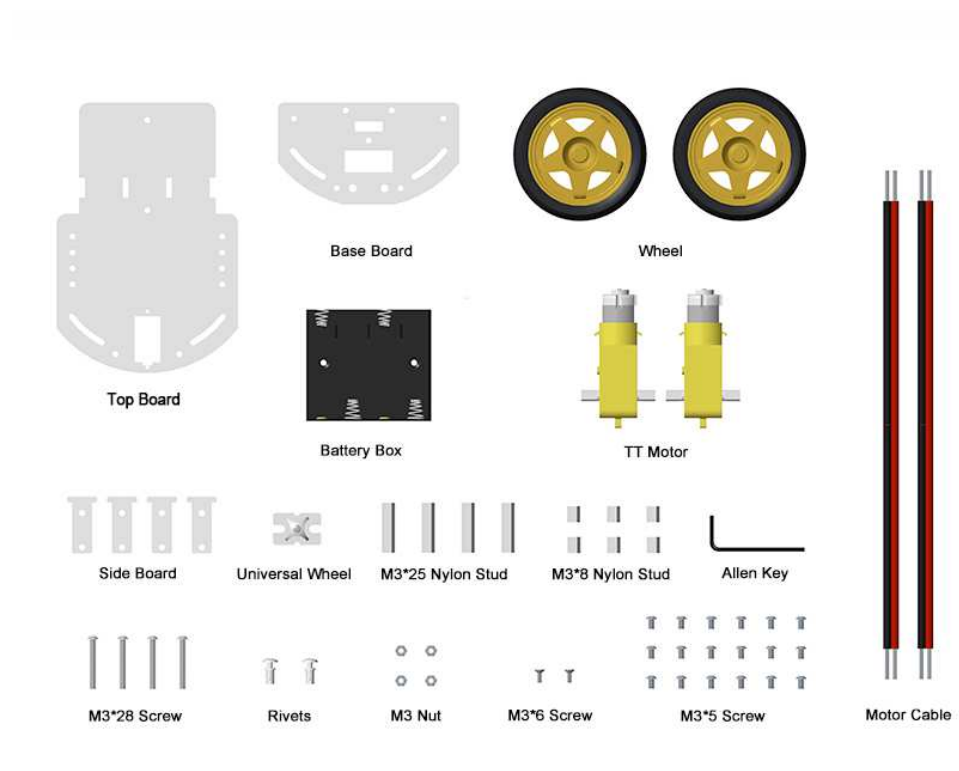

Component	Quantity(pcs)	Note
Top Board	1	—
Base Board	1	—
Side Board	4	—
Wheel	2	—
TT Motor	2	—
4 AA Battery Box	1	—
Universal Wheel	1	—
M3x25MM Hollow Nylon Stud	4	—
M3x8MM Hollow Nylon Stud	6	—
M2.0 L Type Allen Key	1	—
R4090 Nylon Rivets	2	—
M3 Nuts	4	—
M3x28 Hexagon Screws	4	—
M3x6 Countersunk Hexagon Screw	2	—
M3x5 Hexagon Socket Screw	20	2 supplements
Assembly Drawing	1	—

Item	Parameter
Motor Category	TT Motor
Drive Wheel	2
Battery Box	Require 4 AAA Batteries
Net Weight	210g
Size of Finished Product	146mm x 124mm x 71mm

